

## 500 Litre -86°C Ultra Low Temperature Freezer, Dual Compressor

**Product Code: MDULF-50086**

This 500 Litre MDULF model is one of the most advanced and secure ultra-low temperature freezers for the storage of your invaluable samples.

The LabCare+ range of -86°C Ultra Low Temperature Freezers satisfy the demand for safe, long-term storage of highly-valued materials and samples.

Two independent refrigeration systems, combined with an optional liquid CO<sub>2</sub> backup system, provide a critical level of protection that is unmatched in the marketplace.

By using two independent refrigeration systems, the LabCare+ ULT freezers reliably maintain a stable, set temperature down to -86°C. Should either cooling system suffer from any unexpected failure, the other circuit (compressor) will maintain a temperature of -80°C thus keeping all samples safe until service can be arranged.



### Features

#### **DIGITAL CONTROLLER**

5" Graphic LCD touchscreen. Providing easy programming and greater accuracy of temperature control.

#### **TEMPERATURE**

Temperature control range from -40°C to -86°C with datalogger and USB data download port.

#### **SAFETY**

Maximum protection thanks with visual and acoustic alarm signals, used in case of power failure, temperature deviations, probe failure, open door after 10-60 seconds, low battery or filter saturation.

#### **100% TESTED**

All condenser units are tested in helium chambers to check for refrigerant leaks.

#### **REFRIGERATION**

Double circuit cooling system, with independent and hermetically sealed, low-noise compressors. In case of failure of one system, the other can maintain the internal temperature at -80°C. Natural cooling gas HC, biodegradable.

#### **INSULATION**

120mm, high quality, CFC-free, VIP (Vacuum Insulation Panel) insulation. Solid door with lock and 4 inner doors to help maintain cabinet temperature during openings.

#### **CERTIFIED**

AENOR audited and certified by internationally recognised firm. ISO 9007:2015 (Quality); ISO 14001:2015 (Environmental); OSHAS18001:2007 (Prevention and Worker Safety).

## Specifications

Core Elements	
Operating Temperature (°C)	-40 / -86
Net Capacity	500
External Dimensions; W x D x H (mm)	996 x 919 x 1986
Internal Dimensions; W x D x H (mm)	640 x 621 x 1300
Door Opening; W x H (mm)	666 x 1297
Cabinet Construction	
Exterior Material	Powder coated, galvanised steel
Interior Material	AISI 304 stainless steel
Interior Construction	<ul style="list-style-type: none"> <li>- Internal structure made of stainless steel, AISI 304</li> <li>- Pressed inner guides, rounded interior corners, 3 access ports</li> </ul>
Insulation	Polyurethane with high density 40Kg / m <sup>3</sup> , CFCs free, zero ODP and low GWP
Insulation Thickness (mm)	120 + VIP
Features	
Doors	Outer 1 / Inner 4
Door Construction	<ul style="list-style-type: none"> <li>- Solid hinged door with integrated handle, key lock and front document holder</li> <li>- Single-handed operation</li> <li>- Easy to replace double door gasket</li> <li>- Door open sensor</li> </ul>
Door Lock	✓
Door Frame Heater	✓
Shelving	3
Compartments	4
Shelf Dimensions; W x D (mm)	617 x 553
Shelves/Drawers Material	AISI 304 stainless steel
Feet	Adjustable feet with lockable castors
System	
Digital Plus Controller	<ul style="list-style-type: none"> <li>- Temperature range -40°C / -86°C</li> <li>- PT1000 temperature probe with precision of 0.1°C on the display</li> <li>- Audible and visual warning functions in case of:               <ul style="list-style-type: none"> <li>Maximum and minimum temperature deviation</li> <li>Power failure, Probe failure, Open door</li> </ul> </li> <li>- Volt-free contact</li> <li>- USB port</li> <li>- RS485 remote control interface port</li> <li>- Datalogger (historical alarms and temperatures)</li> </ul>
Back Up Battery	48 hours
Defrost	Manual
Condensation	Forced air
Evaporation	Forced air evaporator with anti-corrosion epoxy coating

Technical Features	
Refrigerant	R600a / R1150
Power Supply	230V / 50 Hz
Refrigeration Capacity (W)	723
Power Consumption (kWh/24h)	14.50
Nose Level (dB)	51
Dimensions	

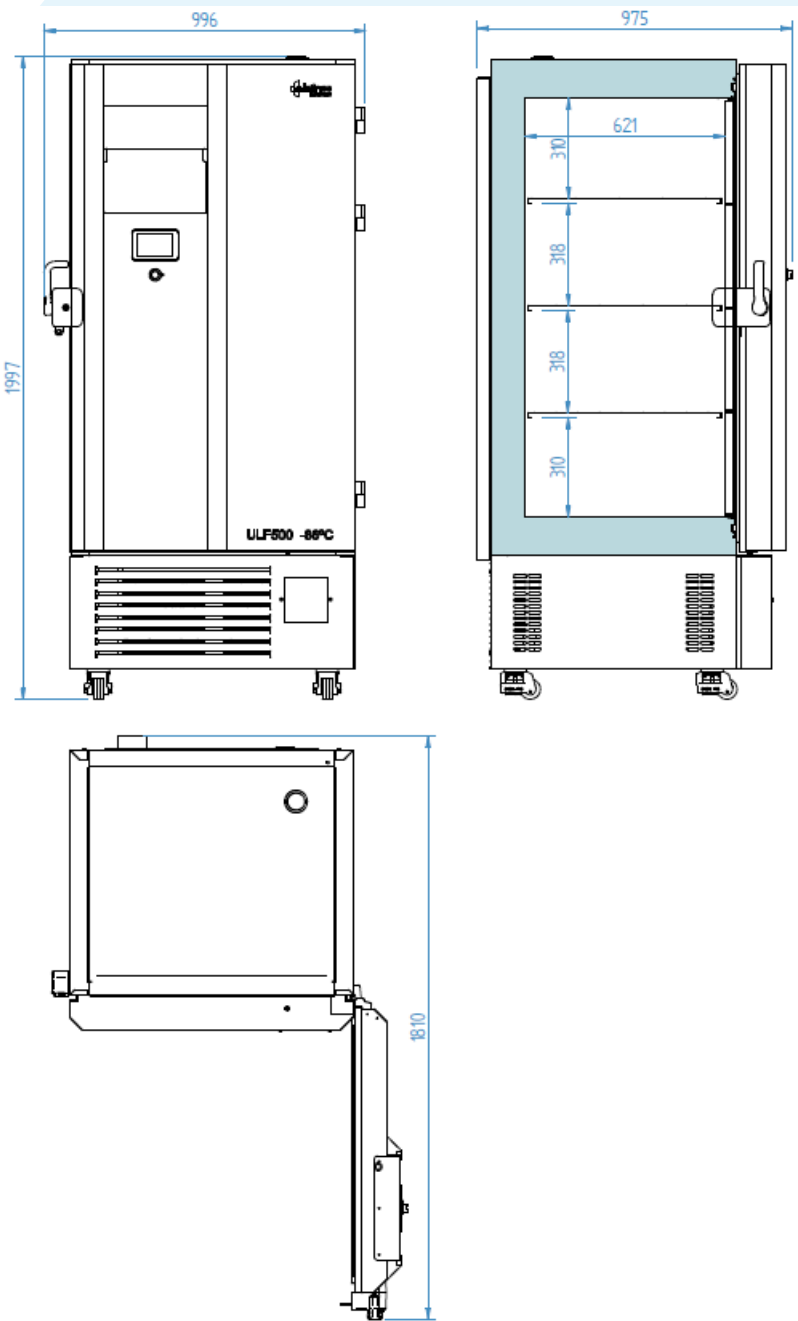

### Accessories

- Electrical connection 230 V / 1 ph / 60 Hz
- Electrical connection 115 V / 1 ph / 60 Hz
- Special plugs available
- 5 Inner doors / 4 shelves
- Temperature chart recorder
- Bluetooth datalogger
- WiFi datalogger
- CO<sub>2</sub> backup
- Side Access rack 50/75/100mm
- Sliding rack 50/75/100mm
- Cryogenic gloves

Unit 3, Tower Business Park  
 Warpsgrove Lane  
 Chalgrove  
 Oxfordshire  
 OX44 7XZ

Tel: +44 (0) 1865 400321

Email: [enquiries@medlinescientific.com](mailto:enquiries@medlinescientific.com)  
 Website: [www.medlinescientific.com](http://www.medlinescientific.com)

